

Models
29ss/35ss
Walk Behind Scrubber
Specifications

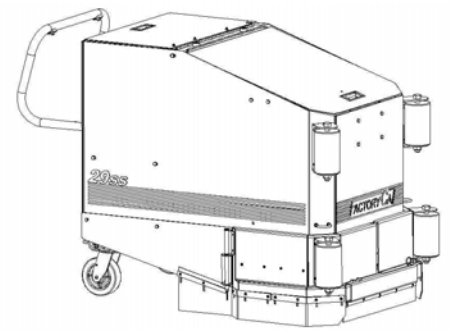

29

35

BODY CONSTRUCTION/DIMENSIONS

| | | |
|------------------------|------------------|-----------------|
| Tank Construction | 7/16" Poly | 7/16" Poly |
| Chassis Construction | 3/16" (Steel) | 3/16" (Steel) |
| Drive Wheel | (2) 11" x 4" | (2) 11" x 4" |
| Casters | (2) 6" x 2" | (2) 6" x 2" |
| Dimensions (L x W x H) | 57" x 31" x 43" | 57" x 35" x 43" |
| Length | 32", 35", or 38" | 38" or 45" |
| Weight (w/o batteries) | 662 Pounds | 685 Pounds |
| Weight (w/batteries) | 1,152 Pounds | 1,175 Pounds |

BRUSH/PAD SYSTEM

| | | |
|---------------------|--------------------|--------------------|
| Brush/Pad Diameter | (2) 15" | (2) 17" |
| Motor (hp and rpm) | (2) 1.0 hp/350 rpm | (2) 1.0 hp/350 rpm |
| Pressure Settings | (1-5) Automatic | (1-5) Automatic |
| Brush Down Pressure | 0-200 pounds | 0-200 pounds |

BATTERY SYSTEM

| | | |
|---------------------|-------------------|-------------------|
| Battery Count | 4 | 4 |
| Battery AH Rating | 396 amp hour | 396 amp hour |
| Battery Description | 6-volt deep cycle | 6-volt deep cycle |
| Battery Run Time | Up to 5 hours | Up to 5 hours |
| Charger | 24 volt/36 amp | 24 volt/35 amp |

SOLUTION SYSTEM

| | | |
|------------------------|------------------|------------------|
| Solution Tank Capacity | 30 gallons | 30 gallons |
| Solution Flow Rate | 0 - .75 gal/min. | 0 - .75 gal/min. |
| Solution Drain Hose | 1" Diameter | 1" Diameter |
| Solution Filter | Inline/Stainless | Inline/Stainless |

RECOVERY SYSTEM

| | | |
|------------------------|-----------------|-----------------|
| Recovery Tank Capacity | 30 gallons | 30 gallons |
| Vacuum Horsepower | 1.0 hp, 3-stage | 1.0 hp, 3-stage |
| Water-lift | 68" | 68" |
| Clean-out Door | 5" Diameter | 5" Diameter |
| Recovery Drain Hose | 2" Diameter | 2" Diameter |

DRIVE SYSTEM

| | | |
|-----------------------|------------------|------------------|
| Transaxle Description | 7.5 hp, sealed | .75 hp, sealed |
| Speed Control: | Variable 0-230ft | Variable 0-230ft |

PRODUCTIVITY

| | | |
|--------------------|--------------|--------------|
| Cleaning Width | Disk: 29" | Disk: 33" |
| Cleaning Rate/Hour | Disk: 29,000 | Disk: 33,000 |

RPS Corporation
P.O. Box 241
Racine, Wisconsin 53401
Phone: (800) 634-4060
Fax: (800) 901-3335

www.factorycat.com
Copyright RPS Corporation 2003. *All Rights Reserved. Since our policy is one of constant improvement, all specifications are subject to change without notice.*

AUTHORIZED DISTRIBUTOR